

# HIGH SPEED U TYPE LABEL SENSOR

SU-02  
series

- ※ High Speed Response : 10 KHZ
- ※ Label Non - Transparent Tape Detectable.  
< SU-02X >
- ※ Mark ON Transparent Tape Detectable.  
< SU-02R >
- ※ Suiting For Label Machine or Packing Machine.



## Specification

Model	SU-02X	SU-02XP	SU-02R	SU-02RP
Output Method	NPN	PNP	NPN	PNP
Emitter	Infrared LED		Red LED	
Operating Voltage	10~30 VDC ; Current Consumption 40mA max.			
Output Current	150mA max.			
Output Status	NO			
Sensible Object	Non - Transparent Object		Transparent Object	
Response Frequency	10KHZ			
Illumination	Lamplight < 3,000 Lux ; Sunlight < 5,000 Lux.			
Connection Method	3 Cores / 4.0φ X 2m			
Housing Material	PC Plastics			
Operating Temp./Hum.	-20 C~+70 C ; 35%~85% RH			
Sensitivity Adjuster	270 Trimmer			
Output Circuit & Connection Diagram	<p><b>NPN</b></p>		<p><b>PNP</b></p>	
Dimension				
	Weight : 65g			

- ※ WHITE LIGHT MARK SENSOR  
EASY TO DETECT THE "GREEN" OR "RED" MARK
- ※ HIGH STABILITY & RELIABILITY
- ※ LOW COST & HIGH QUALITY



## SPECIFICATION

TYPE 型式	MARK SENSOR			LABEL SENSOR
Model 型號	SU-07W	SU-07G	SU-07R	MU-07X
Emitter 發射光源	White Led	Green Led	Red Led	Infrared Led
Operating voltage 工作電壓	10-30 VDC; Ripple < 20% of peak to peak			
Current consumption 消耗電流	30 mA max.			
Sensitivity adjuster	270° Trimmer			
Output method 輸出方式	NPN & PNP two output			
Output current 輸出電流	150 mA max.			
Output status 輸出狀態	Standard : NO Type ; SU-07 -B : NC Type			
Protection circuit 保護迴路	Short Circuit & Polarity Reversed Protection			
Sensible object 可被檢測物	Transparent Object			Semi-Transparent
Min.sensible object 最小可檢測物	2.0 φ			
Response frequency 響應頻率	1 K Hz			
Illumination 耐外亂光	Lamplight <5000 LUX ; Sunlight < 10,000 LUX			
Connection method 接線方式	4 φ / 4 φ X 2m			
Housing material 外殼材質	Intensive ABS			
Operating temp/hum 工作環境	-20°C ~ + 60°C ; 35% ~ 85 % RH			
Protection 保護等級	IP-65			

## Output Circuit & Connection Diagram

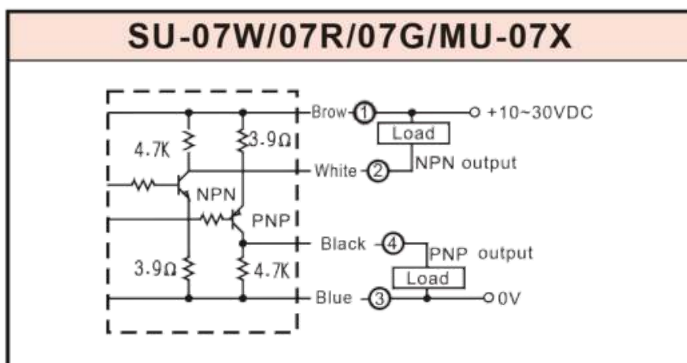

## Dimension

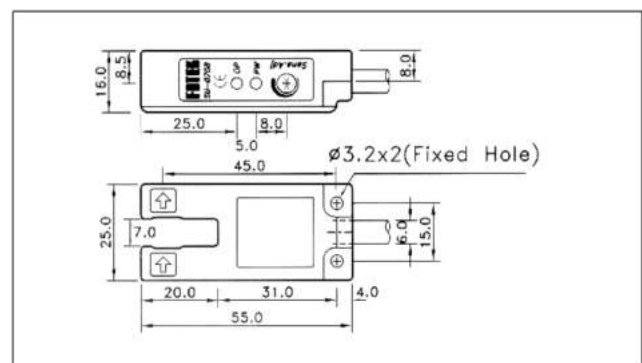

# U TYPE HIGH SPEED GEAR SENSOR

SU-07X series

- ※ HIGH SPEED RESPONSE : 5 KHz
- ※ HIGH STABILITY & RELIABILITY
- ※ LOW COST & HIGH QUALITY



## SPECIFICATION

Model	型號	SU-07X	SU-07XP
Output method	輸出方式	NPN	PNP
Operating voltage	工作電壓	10-30 VDC; Ripple < 20% of peak to peak	
Current consumption	消耗電流	30 mA max.	
Output current	輸出電流	150 mA max.	
Protection circuit	保護迴路	Short Circuit & Polarity Reversed Protection	
Emitter	發射光源	Infrared Led	
Min.sensible object	最小可檢測物	1.0 $\phi$	
Response frequency	響應頻率	5 K Hz	
Illumination	耐外亂光	Lamplight < 5000 LUX ; Sunlight < 10,000 LUX	
Connection method	接線方式	4 $\phi$ / 3 $\phi$ X 2m	
Housing material	外殼材質	Intensive ABS	
Operating temp/hum	工作環境	-20°C ~ +70°C ; 35% ~ 85 %RH	
Protection	保護等級	IP-65	

## Output Circuit & Connection Diagram Dimension

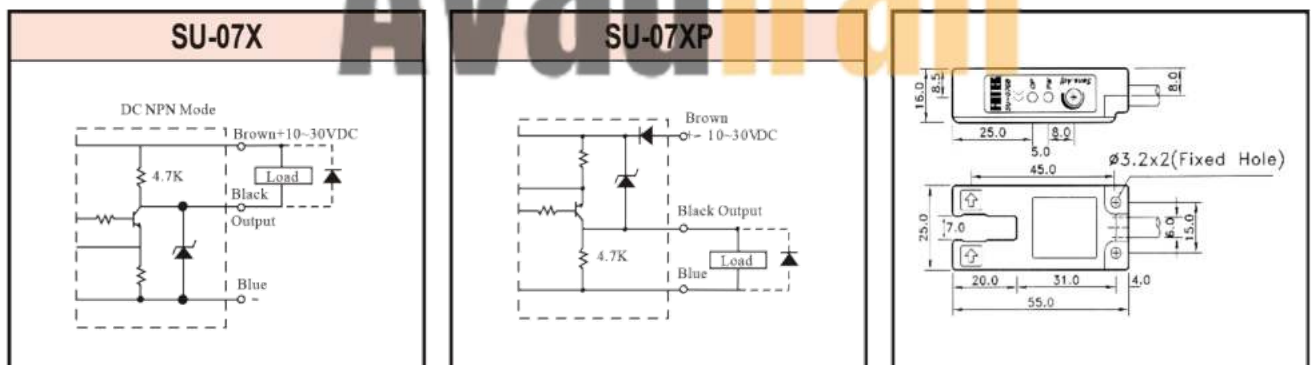

## ◆ Specification / 規格

Model	型號	SU-30X	SU-30XP
Output method	輸出方式	NPN	PNP
Detecting distance	開口寬度	30mm	
Emitter	發射光源	Infrared LED	
Detectable object	最小檢測物	Opaque object 4.0 $\phi$ min.	
Sensitivity adjuster	感度調整	non	
Operating voltage	工作電壓	10 ~ 30VDC	
Ripple of power	電源漣波	20% peak to peak	
Current consumption	消耗電流	30mA max.	
Response time	反應時間	1.0 ms max.	
Output status	輸出狀態	NO/NC changeable	
Output current	輸出電流	150mA max.	
Residual voltage	殘留電壓	0.1V max.	
Leakage current	洩露電流	0.8mA max.	
Protection circuit	保護電路	Short circuit & polarity reversed protection	
Housing material	外殼材質	Aluminum alloy / 鋁合金	
Noise resistance	抗干擾	2kv/1 $\mu$ s	
Dielectric strength	電介強度	2.5kv / 1 minute min.	
Insulation strength	絕緣強度	100 M $\Omega$ / 500vdc	
Operating circumstance	工作環境	-20 $^{\circ}$ C ~ +80 $^{\circ}$ C ; 35% ~ 85% RH	
Protection class	保護等級	IP-65	
Approval	認證	CE	

## ◆ Output circuit & connection diagram & Dimension / 輸出回路 & 接線圖 & 外形圖

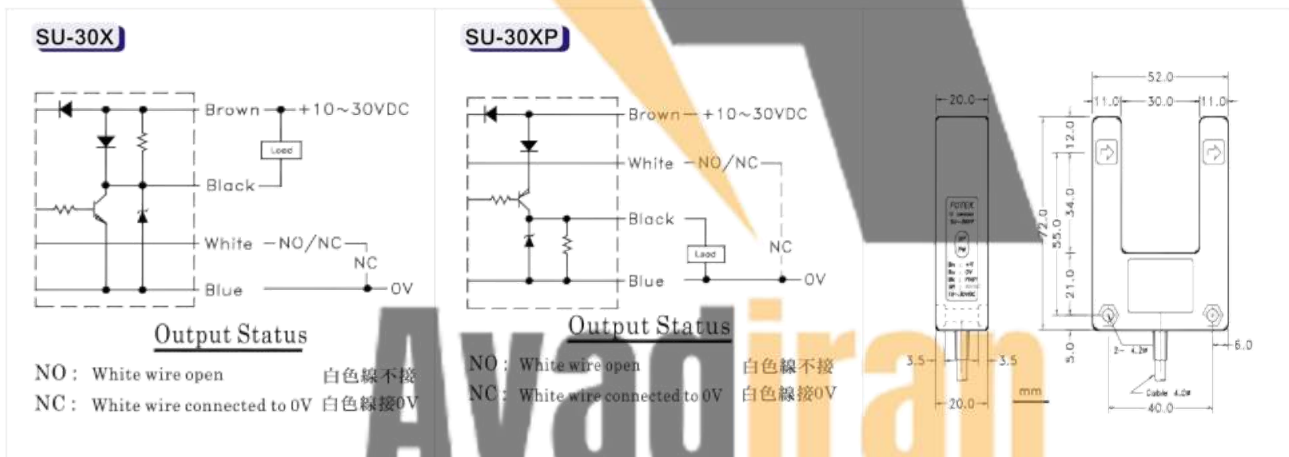

陽明電機股份有限公司  
**FOTEK CONTROL CO., LTD.**